

HC-1200/3 type Overhead Conveyor type Shot-blasting Chamber Machine



Application

The HC-1200 type shot blasting machine has been developed for surface cleaning of castings, forged parts, and smaller welded structures.

Description

The machine is equipped with three pieces of ABR-D400 impeller wheel type turbines.

They are arranged to blast in different parallel planes to assure a proper blast-cleaning effect on the entire surface of the work-pieces.

The turbines are of gravity abrasive feeding ones, having mechanic accelerator, control cage and 8 blades placed between two discs, thus assuring an accurate abrasive jet direction adjustment opportunity.

The work-pieces to be cleaned are hanged onto a hand moved hanger device which will be brought into the middle point of the blasting chamber. During cleaning with closed inlet door the hanger device will stationary rotate in front of the turbines.

We supply two pieces of hangers fitted on the Y-shaped conveyor path to assure, that work pieces can be replaced on one during the blasting time of the other one.

The chamber internal surfaces in access of the active abrasive jet are covered with highly abrasion-resistant manganese steel plate, while other surfaces are protected with thick wear resistant rubber cover.

Blasting will only be possible, whenever the door is closed; this door assures proper protection against abrasive particles flying out.

The continuous and closed flow loop of abrasive is assured by a collecting hopper with screw, bucket elevator, windscreen, dosing unit and turbines.

For optimum surface cleanness the quantity and jet direction of the blasted abrasive can be accurately adjusted.

The ready parts hanger can be removed from the cabinet by hand after opening the door, and it can be simply replaced with the next charge.

To exhaust and filtrate the created dust during blast-cleaning we supply a bag type filter c/w fan and suitable ductwork.

A central control board will be supplied for controlling all functions of the machine.

Normal operation shall be carried out in automatic set position, however there is hand operation option also provided for service functions.

Blasting pattern

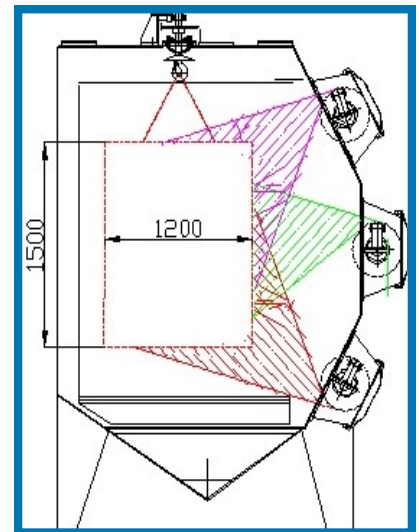

HC-1200/3



Measure print / HC-1200/3 /

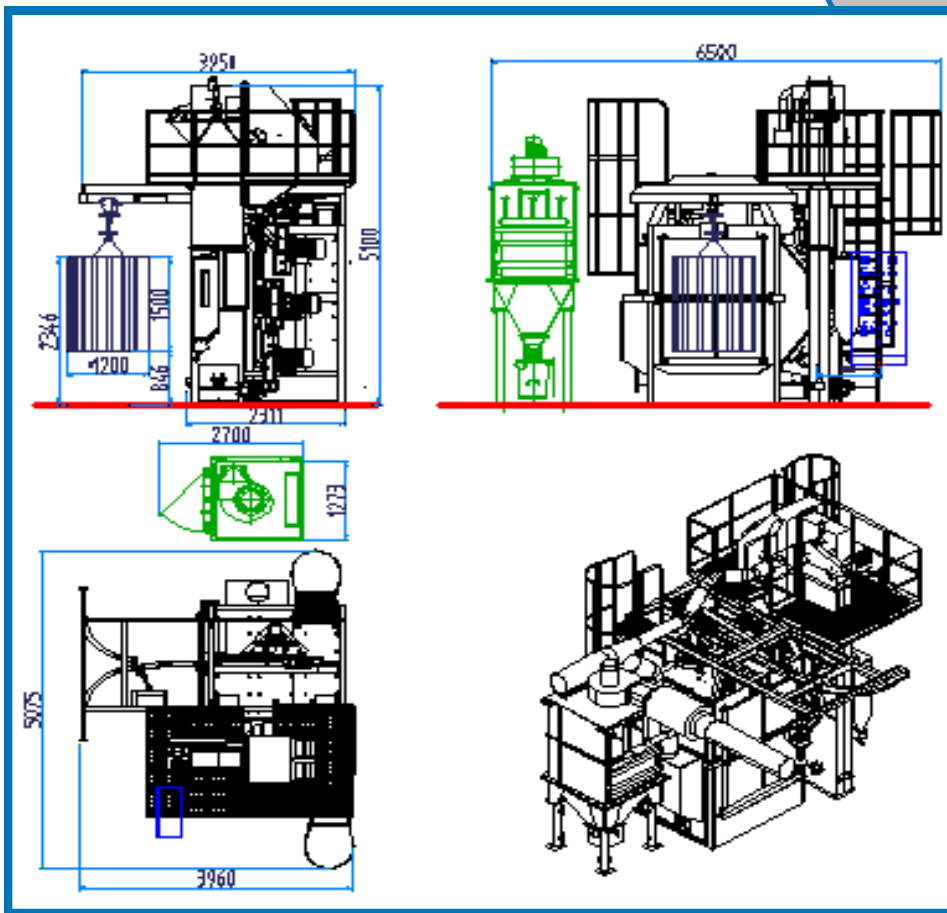

Technical data

Work piece-hanger theoretical max. measures:			
	Height	mm	1500
	Diameter	mm	1200
Turbines:	Quantity	pc	3
	Type	ABR-D400	
	Wheel diameter	mm	400
	Wheel speed	RPM	2400
	Abrasive capacity	kg/min/	180
	Turbine motor power	kW	7,5 /each
Conveyor path:	Load capacity	kg/hanger	500
Supply requirements:	Electrical	Machine	kW
		Aspiration	kW
	Compressed air	Pressure	bar
		Air volume	m ³ /h
Abrasive charge:		kg	1500
Recommended abrasive particle size:		mm	0,4-1,2
Aspirator fan capacity:		m ³ /h	5000
Electric data:	Voltage	V	3 x 400
	Control voltage	V	220
	Cycles	HZ	50